



Current treatment options for Parkinson's disease and the existing status of nanotechnology

Kannekanti Teja¹, Asha Spandana K M^{*1}, Amit B Patil¹, Vishakante Gowda D¹, Narahari Rishitha²

¹Department of Pharmaceutics, JSS College of Pharmacy, Mysuru, India

²Department of Pharmacology, JSS College of Pharmacy, Mysuru, India



Article History:

Received on: 12.08.2019

Revised on: 02.11.2019

Accepted on: 15.11.2019

Keywords:

Parkinson's disease,
Neurodegenerative disorder,
Gene therapy,
Nanotechnology

ABSTRACT

Parkinson's disease (PD) is a neurodegenerative disorder associated with dopaminergic neuron degeneration and/or loss of neuronal activity. Current idiopathic PD treatments focus primarily on the use of pharmacological agents to improve PD patients' motor symptoms. PD remains to be an incurable disease so far. Therefore, the development of new therapeutic approaches for PD therapy is of utmost significance. Several molecular and gene therapy methods have been established over the past 20 years to counteract or retard the development of PD. Severe side effects are found in many native therapies. Therefore, novel therapeutic strategies remain in demand for development. Nanomedicine seems to be a significant medical application in nanotechnology that demonstrates promising future in drug delivery to the central nervous system. BBB stands throughout the central nervous system as a gateway to drug targeting. Drug delivery, based on nano-particles that always avoids Blood-Brain Barrier protection, Different potential therapies based on nanoparticles and nanosystems are explored various benefits. The scope of this review is to provide an overview of this field of PD-related therapies and significant breakthroughs. To do so, this review will begin by concentrating on PD characterization, pathophysiology, etiology and present therapy choices that subsequently cover molecular, gene therapy, and nanotechnology formulations that are currently being studied in animal PD models or lately tested in clinical trials.

*Corresponding Author

Name: Asha Spandana K M

Phone: +91- 9486397829

Email: asha@jssuni.edu.in

ISSN: 0975-7538

DOI: <https://doi.org/10.26452/ijrps.v11i2.2232>

Production and Hosted by

IJRPS | www.ijrps.com

© 2020 | All rights reserved.

INTRODUCTION

Parkinson's sickness (PD) is a dynamic disorder portrayed by a moderate and specific loss of neurons.

side effects include akinesia and somewhat rhythmic, muscle contraction and relaxation involving oscillations or twitching movements of one or more body parts, In simple words, Parkinson disease is paralysis condition it is a syndrome of various reasons and its important features are akinesia, muscular rigidity, bradykinesia, loss of associated movements And trembling in hands, arms, legs, seborrhea, memory loss, Anti Parkinson medications will only help to relieve the symptoms of Parkinson disease and improve the Quality of life. PD treatment varies depending on the era of the patient, the phase of the disease, and the most problematic symptoms of the patient. The Society of Japan's guidelines suggests that therapy of symptomatic PD starts with levodopa or dopamine agonist. Although levodopa is efficient in alleviating PD symptoms, sev-

eral patients with levodopa experience wearing-off phenomena due to decreased duration of the therapeutic benefit of each dose of levodopa. Severe side effects are found in many native therapies. Therefore, novel therapeutic strategies remain in demand for development. Advances in nanotechnology has led to the development of Nano lipid molecules as drug carriers that can effectively cross the natural anatomic and physiological barriers and result in an increase in bioavailability in the targeted tissues (Hattori *et al.*, 2018).

Pathophysiology

Parkinson's disease (PD) is characterized, especially in mesencephalon, as there will be slowly neuronal degeneration takes place. The reasons are an unknown, but the genetic and toxic risk Factors are found. A significant pathophysiological characteristic in PD is the destruction in the substantia nigra (SN) leads to loss of the dopaminergic neurons, resulting in a particular disorganization of the complex basal ganglia (BG) circuits. Due to damage to dopaminergic neurons, there will be a decrease in the synthesis of dopamine neurotransmitter which leads to alteration in motor nerve activity.

Not only the above condition but also, in some cases, epidemiology reports say that in some patients due to excess of acetylcholine levels and because of the high action of acetylcholine causes Parkinson's symptoms. Evidence now indicates that the association of chronic neuroinflammation with PD pathophysiology is consistent. Microglia activation and enhanced concentrations of pro-inflammatory mediators such as TNF- α , IL-1 β and IL-6, reactive oxygen species, and eicosanoids were reported from PD patients and animal models of PD after post-mortem assessment of substantia nigra (Collins *et al.*, 2012).

Factors which effects the deterioration of dopaminergic neurons

The factors that affect most of the cells (pancellular variables), especially genetics and environmental toxins, have dominated public discussion of disease etiology in the latest years. While there is compelling evidence to support a link between the danger of disease and these variables, it is hard to explain the pattern of neuronal pathology and cell loss without cell-specific variables. Some main factors like age, genetic mutations, and environmental factors, as shown in Figure 1, (Caviness, 2014).

Etiology

In our biological system (4-phenyl- 1 methyl 1, 2, 3, 6-tetrahydropyridine), which is nothing but tetrahydropyridine, which produces irreversible Parkin-

son's syndrome. Thus it means neurotoxicity is due to the development of MPP + by MAO-B, which is framed at glial cells because of the Interception of MPP + in dopaminergic neurons, the mitochondrial complex in neuron get deformation and leads to the development of free radicals.

These progressive occasions lead to substantia nigra (SN) dopaminergic neuronal misfortune and thereby, retrospective degeneration of terminals and soma in neuron takes place Which causes severe Parkinson's symptoms it has been prescribed that PD may be a direct result of one or more xenobiotic substances like MPTP. Which will explicitly harmful to dopaminergic neurons. Various examinations describe that toxication can also occur with exposure of n-hexane, which prompts a parkinsonian issue (Bulck *et al.*, 2019).

Current treatment strategies

Till now, there is no appropriate treatment for Parkinson's disease at the early stages. Meanwhile, we can only manage the symptoms, and hence by that medication, we can maintain quality of life later physician suggests the surgery to the brain in order to regulate and modifications at certain regions in basal ganglia, which predominantly improve the symptoms of Parkinson disease. As we know based on causative reasons for the disease, its treatments are designed.

Levodopa

Levodopa is a dopamine precursor. It is an effective and well-tolerated dopamine replacement agent, it remains the gold standard to treat *Parkinson's* symptoms. The main symptomatic and the primary treatment for the dopaminergic shortage was the administration of L-Dopa; it was given by the combination of a dopa decarboxylase inhibitor.

The reason behind the combination therapy is dopamine readily gets metabolized with dopa decarboxylase enzyme present across brain and exists in peripheral areas thus the Peripheral dopa decarboxylase will metabolizes the levodopa before enter into blood-brain barrier, so the researchers suggest that it is necessary to administer levodopa with dopa decarboxylase enzyme inhibitors, in order to irradiate the problems associated with metabolic enzymes, Long term use of levodopa lead to motor fluctuations and Drug-induced dyskinesia to overcome this problem of motor fluctuations, In an attempt to solve these motor complications, dopamine receptor agonists started to be administered, either alone or as combinatorial therapy with L-DOPA. The mechanism action of Levodopa as shown in Figure 2, (Poewe *et al.*, 2010).

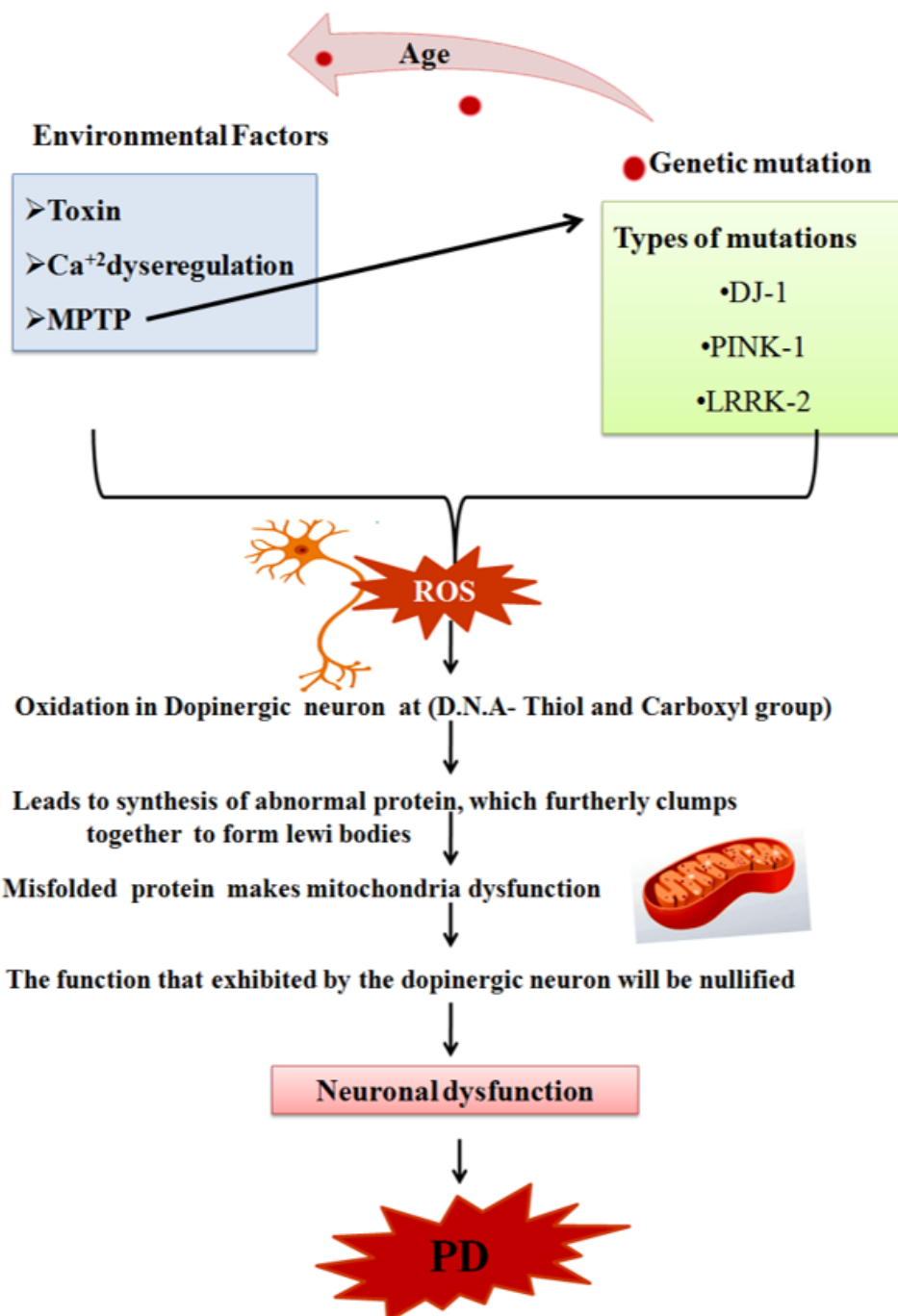

Figure 1: Factors which effects the deterioration of dopaminergic neurons

Dopamine agonist

Parkinson's disease (PD) is multiple complex issues like age-related factors, genetics, and a decrease in the dopamine levels, which can be managed by using dopamine agonists. 90% of PD patients are most of the above 60 years of age and may have clinical symptoms exacerbated by age-related comorbidities or a decrease in physiological compensatory organs. Levodopa is replaced with a dopamine agonist in the current scenario due to the adverse effects. The synthetic, semisynthetic, or naturally

obtained chemical constituents will act as dopamine agonists and have similar effects as dopamine. There are 10 dopamine agonists available for the treatment of Parkinson's disease. However, there are six orally acting dopamine agonists accessible in that Four is ergot subsidiaries: bromocriptine, pergolide, alpha di hydro ergocriptine, cabergoline and lisuride and two non-ergot drugs: ropinirole and pramipexole Rotigotine is a non-ergot agonist accessible by the transdermal fix. These medications all work by incitement of the post-synaptic dopamine receptors. The dopamine agonists were

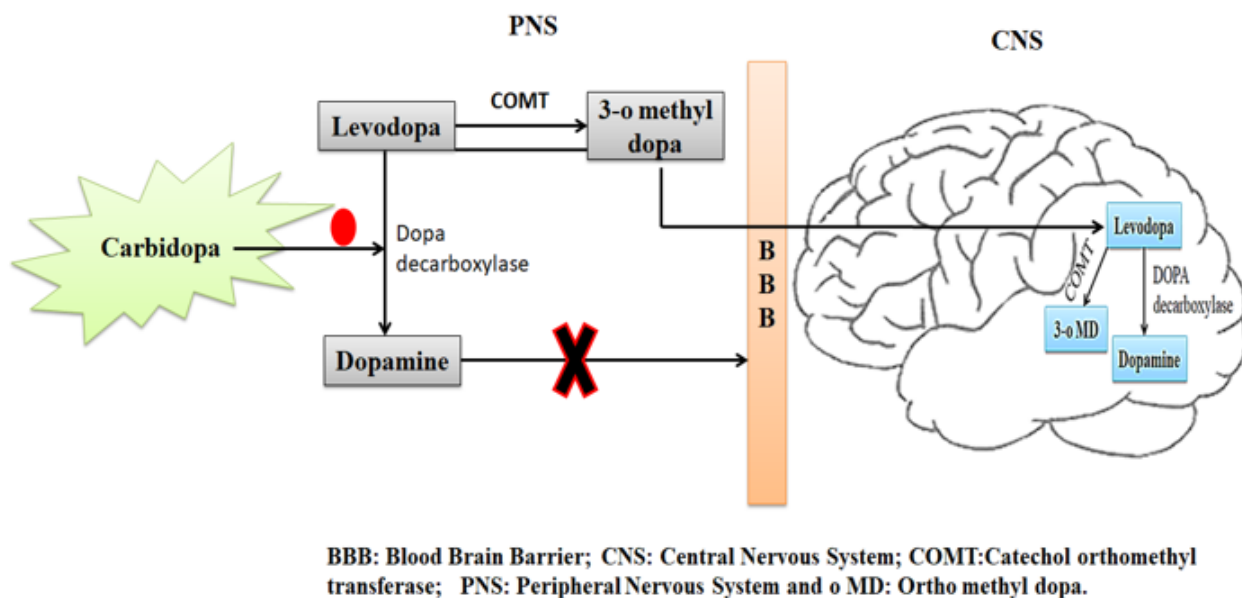

Figure 2: Mechanism of Levodopa

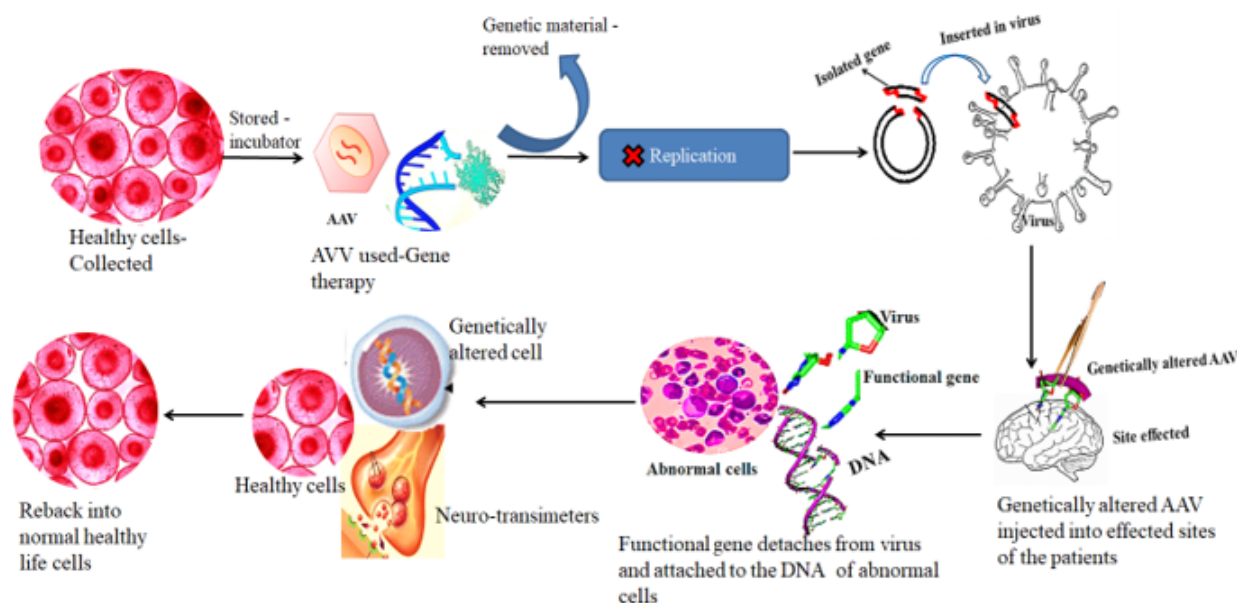

Figure 3: Steps involved in gene therapy

at first authorized for use related to levodopa in patients with cutting edge PD, dopamine receptors are the site where these dopamine agonists will follow up and gets bind these agonists having high binding affinity than the original dopamine neurotransmitter and hence it vanishes the negative impacts of dopamine, therefore, it is recommended for the treatment of Parkinson's disease (Lajurkar et al., 2018).

Monoamine oxidase inhibitor

3,4-dihydroxyphenylacetic acid is involved in the synthesis of dopamine, but the enzyme monoamine oxidase B is engaged in the metabolic reaction with

3, 4 D.H.P. Later it was again effected (by catechol-O-methyltransferase (COMT) enzyme and finally converted into homovanillic acid, so MAO-B inhibitors have been fused into the restorative routine regimen of dopamine and hence there will be an increase of dopamine concentration in the cerebrum and promotes a decrease in motor manifestations. The first antidepressants were found and introduced into the clinic included monoamine oxidase (MAO) inhibitors. As a result of its side impacts, which include the 'cheese response, in other words, the stimulation of the cardiac, sympathetic activity of

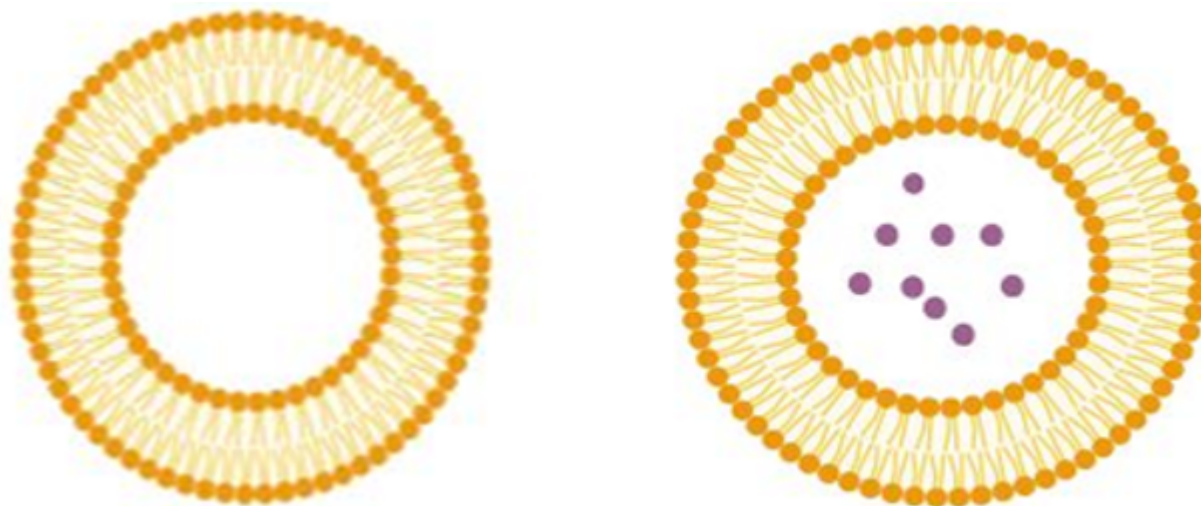

Figure 4: Liposome and drug-loaded liposome

the nervous system owing to nutritional amines

Examples of M.O.B inhibitors are selegiline, sulfonamide, rasagiline (Youdim *et al.*, 2006).

Comt inhibitors

Like inhibition of MAO-B, hindrance of COMT prompts a drastically increased level of dopamine in the midbrain and vanishes the motor symptoms, so it has taken a significant role in the therapy of Parkinson's disease treatment over the past 20 years. Catechol-O-methyltransferase (COMT) inhibitors are used for the therapy of wear-off events in patients with Parkinson's illness (PD), in the early 1980s, various molecules were developed as potent, selective, and reversible COMT inhibitors with nitrocatechol structure. The inhibitors of COMT, namely tolcapone and entacapone, are regarded for the second generation. Regarding beneficial outcomes from clinical studies in patients with fluctuating PD symptoms, PD clinical therapy for wear-off therapy was launched at the end of the 1990s (Muller, 2015). Examples of comt inhibitors are: Tolcapone, Entacapone, and Opicapone

Anticholinergic drugs

In the late 19th century, antimuscarinic alkaloids, particularly for tremor, were found to be beneficial, Synthetic anticholinergics and antihistamines, including trihexyphenidyl (Artane, 1949), mesylate benztropine (Cogentin), hydrochloride procyclidine. Anticholinergic drugs play a vital role for control the tremors in Parkinson's disease patients, drugs such as trihexyphenidyl or boronaphin act as anticholinergics can be utilized as monotherapy or in addition to other antiparkinsonian drugs at the early stages of Parkinson's disease, which has high efficiency of improving motor symptoms, typically

in preventing the tremors. These categories of drugs are used only in the starting stages of Parkinson's disease, which dominates tremors to keep away from an increased risk of dementia. Two approved drugs Benzatropine and trihexyphenidyl, are an anti-parkinsonian agent that reduces acetylcholine activity. Miscellaneous therapies are approved: Several drugs that are non-dopaminergic are used to control symptomatic PD (Zeuner *et al.*, 2019).

Surgeries

Most people with Parkinson's disease are treated with medications although a type of surgery called deep brain stimulation is used, deep brain stimulation involves surgically imparting a pulse generator similar to a heart pacemaker, this is connected to 1 or 2 fine wires placed under the skin and is inserted precisely into specific areas in the brain as the small electric current produces then there will be nerve impulse generation in presynaptic neuron and it facilitates the release of dopamine from neurons for faster polarization of dopaminergic neurons. Deep brain stimulation is the preferred surgical procedure for patients with Parkinson's disease. The globus pallidus interna and the subthalamic nucleus are accepted targets for this procedure. The subthalamic nucleus is more frequently used as the target, demonstrating that this target's neurostimulation yields a better result. After the introduction into clinical practice, many studies have reported on its advantages, disadvantages, and insufficiencies throughout the 15 years. STN-HFS has been shown to be surgically secure despite restricted evidence-based information, and improvements in drug-sensitive dopaminergic symptoms and reductions in subsequent drug dose and dyskinesia are well documented. Moreover, the operation is associated with adverse effects (Hartmann *et al.*, 2019).

Gene therapy

Apart from many treatment options for managing the symptoms of Parkinson's disease the idea of gene therapy techniques and by utilization of this technology we can completely cure the disease but present it is in developing stage, preliminary evidence suggests that an experimental gene therapy procedure has no side effects as like other treatments Genes are segments of D.N.A that directs the cells to produce proteins, these proteins have a wide range of functions in our biological system, many of the diseases are due to improper synthesis of proteins or lack of proteins, if the gene undergoes mutations then it leads to production of abnormal protein which has no function or sometimes it may become toxic to cells. In gene therapy, the functional copy of the gene is delivered into patients at the site where the repair of cells is needed. The functional copy of gene has potential capacity to correct the cause of disease and provide therapeutic benefits, in gene therapy engineered virus is used for delivering the functional genes to effected cells thus the name engineered virus suggests that the toxic nature is discarded in virus, these viral vectors are small, simple virus which never been shown to cause disease in humans (Pires *et al.*, 2017). Steps involved in gene therapy are illustrated in Figure 3.



Figure 5: Polymeric nanoparticle

About blood-brain barrier

Drug delivery to the CNS is an especially difficult task because of three obstacles:

1. The blood-brain barrier;
2. The Blood Cerebrospinal Fluid Barrier (BCSFB) and
3. The Barrier to Blood Tumors(BTB)

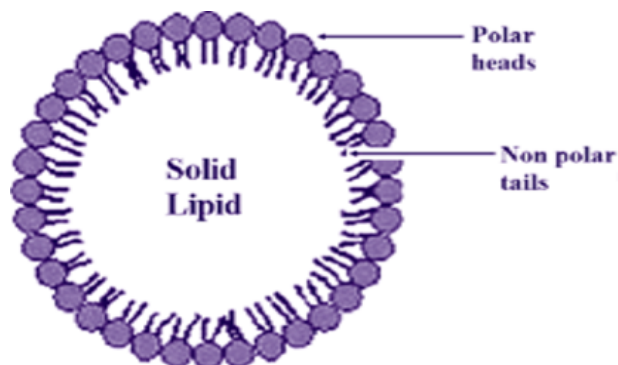

Figure 6: Solid Lipid Nanoparticles

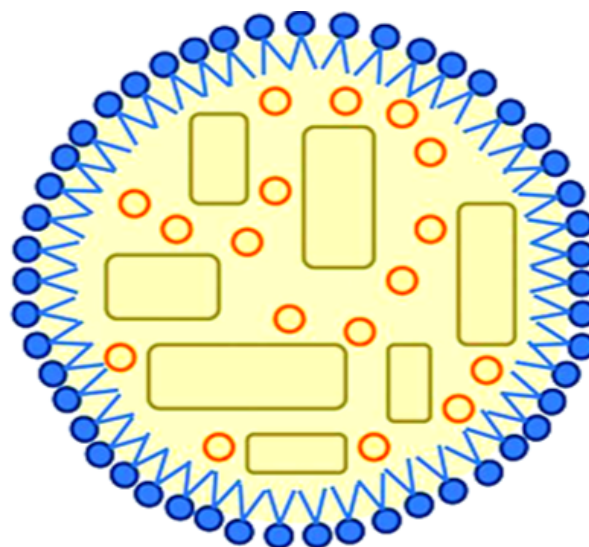

Figure 7: Nanostructured lipid carrier

It is now well identified that the BBB is a distinctive membrane barrier that separates the brain closely from the circulating blood. The blood-brain barrier (BBB) is the specialized system of brain microvascular endothelial cells (BMVEC) that shields the brain from toxic substances in the blood, and it allows only nutrients to the brain tissues. Thus it filters harmful compounds from the brain back to the bloodstream. As a result of restricted permeability, the BBB is a limiting factor for the delivery of therapeutic agents into the CNS (Zaki, 2012).

Characteristics of nanoparticles for delivering the drugs into the brain

Highly lipophilic and tiny molecules could be passively diffused through the BBB. Lipophilicity is often closely related to both the permeability and solubility of a compound; several drug parameters have also been affected by lipophilicity. Strong lipophilicity can lead to the formation of compounds with poor metabolism, and low lipid solubility leads to poor absorption. So, Nanotechnology may be used for drug delivery in such instances. NPS and

nanostructures must have certain characteristics for the delivery of drugs to the CNS (Saeedi *et al.*, 2019).

A description of the optimal features of nanoparticles for drug delivery the C.N.S

Nanoparticles

It acts as a transport vehicle for the delivery of medicine at specific sites. It has several benefits over other colloidal carrier systems, such as drug trapping, extended-release of drugs, enhanced chemical and physical stability, and effective integration of lipophilic drugs into the lipid nucleus of SLNs and NLCs. NPS has been created to regulate and safeguard the release of the drug from enzymatic or chemical degradation to increase its therapeutic effectiveness. Various types of NPS could be used to deliver the drugs and genes to CNS with fewer side effects. Drug formulations for NPS have been created extensively to promote the effective delivery of insoluble medicines to brain cancer cells. Furthermore, PEG frequently modifies the surface of the NPS to improve the stability of the colloidal solution and extend its storage in the body. Nanotechnology offers the opportunity of precise control of cellular drug interactions and *invitro* assessments of cellular reactions in the nervous system based on its molecular interactions characteristic simulation (Saeedi *et al.*, 2019).

Role of nanotechnology in current medicine

The science involved behind nanotechnology is the creation of particles, materials, systems into nanometer. It is a multidisciplinary science, at present nanotechnology is exposed to explosive advancement in many fields. It is hoped that technology would create a new inventions and plays an essential role in numerous medical applications, not only in receptor targeting and drug delivery, however it as additional applications in other fields such as biosensors molecular imaging, biomarkers. The delivery of deoxy nucleic acid, small molecules, peptides, proteins are highly successes by utilization of nanotechnology, this type of novel drug delivery system is a strategical tool for expanding drug market, this innovation can solve the problems associated with current conventional pharmaceutical products. Targeting the drug at a specific site is achieved by designing the drug into a Nanosystem. Thus, the nanoparticles will deliver the drug at the exact receptor site of the diseased organ. Every single chemical constituent has its pharmacological actions as well as toxic effects on other receptor sites of different organs to mask the toxic reaction of the drug at other sites of biological compartments and to maintain the effective therapeutic concentration at the specific predominant site. Hence these are

the best approaches to bring a diverse application in the field of pharmacy. Nanotechnology focuses on itself, making suitable unique systems that can give better medication in small areas of the body. The delivery of medicines by nanotechnology allows the therapeutic agent to penetrate the blood-brain barrier apart from this, there is very important Significance for the expected growth of genetic treatment in the next few years. Further improvements are needed to change the concept of nanoparticle technology into practical application as a realistic approach. Researchers and drug developers have been increasingly focusing on new nanotechnology approaches in upcoming years to enhance drug delivery to the central nervous system (CNS). Nanotechnology has excellent potential to impact neurological disorder therapy, particularly Alzheimer's disease, Parkinson's disease, brain tumors, and several brain strokes. Nanocarriers had also facilitated the targeted delivery of chemotherapeutics in this respect, leading in a successful inhibition of disease progression in malignant brain tumors. The most effective use of nanomaterials in the therapy of CNS disease will improve the overall impact of the drug (Kim, 2007).

Various types of lipid nanoparticles

Liposomes

Liposomes are lipid bilayered membrane vesicles. Natural or synthetic phospholipids are generally used to prepare liposomes, although it is necessary to add other lipids, such as cholesterol or sphingolipids, to the bilayer. Liposomes first suggested in 1965 by Alec Bangham. The word liposome comes from: 'Lipos' (fat) and 'Soma' (body). A liposome consists of a small vesicular structure closely resembling the cell membrane structure. They generally consist of phospholipids, composed of two tails and a region of the head. The head is the hydrophilic part of the molecule, while the tails are the hydrophobic parts of the molecule. Such liposomes are created based on interactions between lipids and lipids.

Furthermore, depending on preparation techniques, the different types of the liposome are broadly classified into unilamellar, multilamellar and giant unilamellar, both hydrophobic and hydrophilic drugs can be incorporated into this liposome. These are incredibly unique structures and liquid entities resulting from extremely particular supramolecular assemblies. Because of their fluidity and dynamic characteristics, liposomal innovation was reportedly used in drug and gene delivery as well as for different analytical and diagnostic applications. Different physical and chemical characteristics of liposomes, such as total net charge, lipid layer packing

mode, hydrophobic/hydrophilic equilibrium, will regulate their stability. The complexity within the liposome layers can be controlled by amplifying the lipid membrane elements. At high temperatures, the liposomal formulation undergoes a liquid transition that it means gel form is converted into liquid, thereby it allows the drug to be released at this high-temperature sites. The reticuloendothelial system (RES), particularly circulating macrophages and Kupffer cells, quickly clears liposomes from the bloodstream when administered by the intravenous route. So to overcome this problem, Nano liposomes are created ([Wakaskar, 2018](#)).

A few of the liposomal formulations produced a good market foray after clinical trials were completed. Some of them enter human trials when the preclinical studies have achieved beneficial outcomes. Because of the extensive development of liposomal technology, more formulations enter clinical trials with a biological predisposition to use these formulations. Its first successful market entry of liposomes was introduced in the year of 1995 of DoxilVR for ovarian cancer and Kaposi's sarcoma patients associated with AIDS after authorization by the regulatory authority. Nexstar Pharmaceuticals (Boulder, CO) subsequently established DaunoX-omeVR, which encapsulated AIDS-treated daunorubicin. The diagrammatic representation of liposome was illustrated in Figure 4, ([Leonard et al., 2009](#)).

Polymeric nanoparticles

Drug delivery, various polymeric platforms were used. Polymeric nanoparticles (NPs) can be designed for a variety of purposes, including protection of the encapsulated material, prolonged-release and targeting the drugs at the predominant site. The word NPs should be regarded general, while we can differentiate Nanospheres from Nanocapsules, by considering the inner and outer morphology if the outer core is made by a strong core matrix, then it is said to be the nanosphere and for Nanocapsules, the polymeric membrane surrounds a liquid core. The biological characteristics of the particles differ significantly in the type of polymer used. Besides, the use of biodegradable and biocompatible materials is needed when considering these NPs for systemic administration. Different polymers have been suggested for brain delivery, such as polyalkylcyanoacrylates (PACAs), polyesters such as poly (lactide) (PLA) and poly (lactide-co-glycolide) (PLGA), and polysaccharides such as chitosan. The diagrammatic representation of Polymeric nanoparticle was illustrated in Figure 5, ([Li et al., 2017](#)).

Solid lipid nanoparticles

An alternative to polymeric nanoparticles was launched as solid lipid nanoparticles (SLNs), these are the first generation of solid lipid carrier structures in the range of nanometers. SLNs seem to be aqueous colloidal dispersions made by a compact matrix from biocompatible and biodegradable lipids which can be filled with a wide range of variety of drugs SLN offers significant benefits such as modulated release, enhanced bioavailability, protection from degradation of chemically labile molecules, cost-effective excipients, enhanced drug incorporation, and broad application spectrum. There are some limitations associated with SLNs; however, such as low drug load capacity, particle growth, during storage, drug leakage occurs. Modifying the SLN surface with hydrophilic polymers like PEG (Stealth SLN) prevents the capture of RES after systemic administration and tends to increase the SLN blood circulation time. Numerous preliminary clinical trials assessed the capacity of SLNs to raise the brain concentration of the drug in vivo in different neurological dysfunction states. An in vivo distribution of doxorubicin with different concentrations of PEG2000 was explored using non-stealth and stealth SLNs ([Muller, 2000](#)).

Various preclinical studies have examined the capacity of SLNs to raise in vivo drug brain concentrations in different neurological diseases. SLNs with multiple PEG200 concentrations in vitro have been explored for in vivo distribution of doxorubicin. An enhanced doxorubicin concentration in the brain was noted in this research when the stealthing agent was augmented. The mechanism of the stealthing SLN transition into the CNS found in an animal model with BBB integrity. The diagrammatic representation of solid lipid nanoparticles was illustrated in Figure 6, ([Zara et al., 2002](#)).

Nanostructured lipid carrier (NLC)

In 1999/2000, NLC was developed by Muller and it took five years for the first two medicines to be introduced in Munich / Germany: Nanorepair Q10 cream (Dr. Rimpler, Wedemark, Germany) and Nanorepair Q10 serum (Dr. Rimpler, Wedemark, Germany). Within half a year, the third product, Nanolipid CLR Restore, was launched in the Chemical Laboratory in Germany. (NLC) is a second-generation smarter drug carrier system. It consists of physiological, biodegradable and biocompatible lipid components and surfactants and has been approved to be used in various drug delivery systems by regulatory officials.

Approximately 30 NLC preparations are currently available. The benefits that NLC has over the other colloid carriers such as nanoemulsions, poly-

meric nanoparticles, liposomes, SLN, etc. are superior. The whole collection of distinctive benefits such as increased drug loading ability, avoidance of drug expulsion, contributes to more flexibility in drug release, enhanced stability during the storage, enhanced permeability and bioavailability, decreased adverse effects, extended half-life and tissue targeted delivery. And makes NLC a versatile delivery system for different delivery routes. For various kinds of drugs that are intended for pharmaceutical, cosmetic and biochemical purposes, NLC is used as biocompatible carriers.

Several drugs or active substances such as lipophilic, hydrophilic molecules, including labile compounds such as proteins and peptides, have been entrapped in NLC over the past century. The broad variety of surfactants, as well as cosurfactants required to produce such particles these carriers are ideal for specific applications such as topical, oral, parenteral, inhalation, and ocular administration. As improvements over SLNs, NLCs were created. The SLNs are made up of solid lipids whereas both solid and liquid lipid is present in NLC, NLC increases the quantity of liquid lipid to form and stack a non-standard type of nanoparticles that leads to a non-perfect lattice and an amorphous structure. With increased liquid fluid, the solubility of active substances can improve and active substances in comparison with SLNs can contribute to better encapsulation. The structure has a greater concentration of liquid lipids than the other constructions. In liquid lipids, drug solubility is greater than in solid lipid. The NLCs can, therefore, accomplish the slow release of drugs and elevated drug loading, thus avoiding losses Before solid lipid decomposition

NLCs are generated by regulating the mixture between solid lipids and liquid oil, which results

In the formation of specific matrix nanostructures.

There are three main techniques in the preparation of NLCs

1. hot homogenization,
2. microemulsion, and
3. cold homogenization

The diagrammatic representation of Nanostructured lipid carrier was illustrated in Figure 7.

Nanocarrier for active brain targeting

To improve CNS delivery, specific ligands are conjugated to the nanocarrier surface. This strategy, also known as a molecular trojan horse, is a mimetic strategy to exchange nutrients between the CNS and

blood under physiological circumstances using the BBB endothelial cells there had been two major transport routes effectively targeted at BBB.

1) Carrier-mediated transport (CMT), through which several vital polar molecules, such as glucose, amino acids, and nucleosides, follows this mechanism

2) Receptor-mediated transcytose (RMT), which may reach the cerebral endothelium through the vesicular transport system by macromolecules such as transferrin (FT) or insulin, on the membranes of BBB endothelial cells, more than 20 transporting proteins have been found in the case of C.M.T they enable the transportation of essential nutrients needed for ordinary brain homeostasis. These carriers are responsible for the delivery of various substrates to C.N.S, such as GLUT1, monocarboxylic acids (MCT1), large neutral amino acids (LAT1), excitatory acids (EAAT), etc. They are responsible for delivering into the brains. For active CNS targeting, CMT may be used for active targeting of C.N.S. (Pardridge, 2005).

Ceramic based nanoparticles

The benefits of nanoparticles produced from ceramic material like silica, alumina, and titanium are higher compared to polymeric nanoparticles. First, its preparations are simple, similar to the best-known sol-gel system and require conditions for ambient temperatures. Secondly, the ceramic material is biocompatible and its sides with various functional groups for the ligand connection can be altered readily. Third, the particles can be designed desirable size, shape, and porosity and highly inert to the external environment the size of ceramic nanoparticles is below 50 nm. There are no pH changes and no swelling or porosity and are not sensitive to microbial assault. Due to extreme pH and temperature, we can safeguard the ceramic nanoparticles from absorbed or adsorbed molecules from denaturation. Ceramic-based nanoparticles to be used in photodynamic therapy as carriers of photosensitizing drugs. This became possible as ceramic nanoparticles are extremely stable and even at severe pH and temperature may not discharge encapsulated molecules. Although the photosensitizers may not be released, the nanoparticles' porous matrices were permeable to molecular and singlet oxygen, thus maintaining the photodestructive action of the encapsulated drugs on irradiation to cancer cells. Controlled trythoxyvinylsilane hydrolysis in micellar media was used to prepare silica-based nanoparticles, the results which we get by the above process will be and spherical and extremely monodispersed (30

nm) were found. Compared to free drugs, the loss of fluorescence of the trapped photosensitizing drug was avoided in aqueous media. These nanoparticles were actively absorbed by tumor cells in vitro, and cells were destroyed by irradiation with visible light (Koo *et al.*, 2005). Silica nanoparticles are currently utilized for forming ternary DNA-dendrimer nanoparticles because they are dense and can concentrate DNA on cell surfaces growing in culture. Silica nanoparticles enable an endosomal lysosomal path for effective uptake of DNA. DNA-reactive silica nanoparticle transfection effectiveness has been improved by a factor of 10 because of this mechanism. The diagrammatic representation of Ceramic based nanoparticle was illustrated in Figure 8, (Zhang *et al.*, 2004).

Albumin Nanoparticles

A significant element of serum protein is albumin. The Albumin surface is accessible for covalent alteration and medication or protein attachment in various amino and carboxylic groups. A desolvation / cross-linking method is used to prepare albumin nanoparticles when dissolved albumin in water is dissolved by adding ethanols and glutaraldehydes downwards, to cause albumin nanoparticles to interconnect over time. An achievement in the medical application of albumin nanoparticles has been accomplished in January 2005 whenever the F.D.A Allowed to prescribe the use of ~130 nm (ABI-007 or Abraxane, American Pharmaceutical Partners, Schaumburg, IL) paclitaxel albumin nanoparticles for the treatment of metastatic breast cancer. Abraxane's general response rate was 33 percent, compared to Taxol's 19 percent.

Albumin nanoparticles for DNA delivery are investigated because in vivo DNA-polyethyleneimine (PEI) - albumin nanoparticles are less toxic than DNA-PEI-structures alone at higher amounts to avoid the opsonization and take-up from MPSs. The diagrammatic representation of Albumin nanoparticle was illustrated in Figure 9, (Chemla *et al.*, 2000).

Magnetic nanoparticles for imaging

Magnetic nanoparticles are a powerful and multifaceted biological and medical diagnostic instrument. They are being used to label certain molecules, cell populations, structures, or microorganisms together with an appropriate antibody. Magnetic immunoassay methods were created, using a delicate magnetometer to detect the magnet field produced by magnetically marked objectives. In magnetic resonance imaging, superparamagnetic nanoparticles are used as contrast agents. They are composed of an inorganic core of iron oxide covered with polymers such as dextran (magnet

Fe₂O₃ and maghemite). The commercial names of Superparamagnetic nanoparticles include a lumen (silicon-coated iron oxide particles with 300 nm in diameter) and endorse (magnetite nanoparticles with a 150 nm dextran diameter) (Sahoo and Labhassetwar, 2003). These contrast agents of nanoparticulate are used for diagnostic purposes, of tissue imaging. The superconductive quantum interference system (SQUID) is a method for the identification of biological targets by super magnetic nanoparticles in a quick way, dextran-formulated colloidal iron oxide is used as MRIs clinically. Current research is however, under manner to continue increasing cellular internalization and subsequent membrane interruptions of tissue relying on and to reducing the toxicity (Koo *et al.*, 2005).

Polymeric micelles

In recent years, for delivering drugs, polymeric micelles have been created. The micelles spontaneously develop in amphiphilic copolymer solutions and display shell-core structures consisting of hydrophobic block polymers as core and hydrophilic block polymers (generally PEGs) as core (L, D-lactone polycaprolactone) (Kim, 2004). The PNPs come from synthetic polymers, such as polyacrylamide and polyacrylate or natural polymers, eg. Albumin DNA chitosan gelatin Because on in vivo behavior, the poly(L-lactide), (PLA) polyphenols (PGA), are considered as biodegradable and non-biodegradables (e.g., polyurethane), Polyester micelles are made up of biocompatible, biological, biodegradable and biological-approved food and drug administration (FDA) polymer such as PEG-poly(lactic acid), PEG- poly(axilla-colic acid)(PLGA) and PEG-poly(caprolactone). As the chain length of hydrophobe poly (lactone) increases, the loading efficacy of indomethacin as a model in micelles improved. Drug releases from hydrophilic lactone like PLA, on the other side, are quicker due to weaker interactions between drug and core poly (lactide).

Shorter PEG4000 chain length improved medication load and decreased the release of medication as compared to PEG10000. It was therefore concluded that various hydrophobicity based on poly (lactone) chemical structure was responsible for the various forces of interaction between medication and the micellar hydrophobic core. The 3 early successes of such lipid-based vesicular drug delivery nanoparticles have resulted in the investigative process and advancement of several different compositions of polymeric nanoparticles, including polymeric micelles, dendrimers, drug conjugates and nanoparticles based on polypeptides and polysaccharides.

Genexol-PM is the first micellar-nanoparticulate polymer in the United States, including [methoxy-PEG-poly (D,L-lactide)Taxol][methoxy-PEG-poly(D, L-lactide) Taxol] in stage II clinical research. The diagram of Polymeric micelles was shown in Figure 10, (Vinogradov *et al.*, 2004).

Nano gels

There may be some inconvenience to existing solid nanoparticles, for example, limited capacity for drug loading and sophisticated preparation steps involving organic solvents. On the other hand, nanogels are made up of flexible nanosized hydrophilic polymers and preparation procedure is very simple. Once the equilibrium attains or swells, the drug can spontaneously be loaded into the nanogel and thus, the solvent volume can be reduced, causing gel collapse and the formation of thick nanoparticles. DNA-nanogel complex formation and stability (below 100 nm) were dependent upon surface charging on the nanogel and ion intensity of the solutions, it was possible to load up to 50% of the macromolecules. After transporting bovine brain microvessel endothelial cells, Vinogradov examines that at least two-thirds of the oligonucleotides are correlated with nanogels. In comparison with free oligonucleotides at fixed concentrations of 5M, the permeability of oligonucleotides was enhanced by up to six times. Further alterations of the transferrin or insulin vector molecules structure leading in rises in 11 to 12 times the permeability. In vivo, Biodistribution has shown that 2.7-5% of the intravenously administered dose is distributed to the intact brain as oligonucleotide-loaded nanogels, compared to 0.2% of the free oligonucleotides (Boas and Heegaard, 2004).

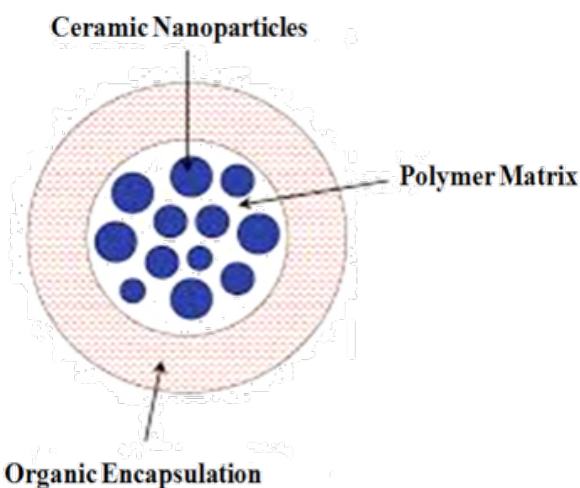

Figure 8: Ceramic based nanoparticle

Dendrimers

Dendrimers are polymer complexes consisting of

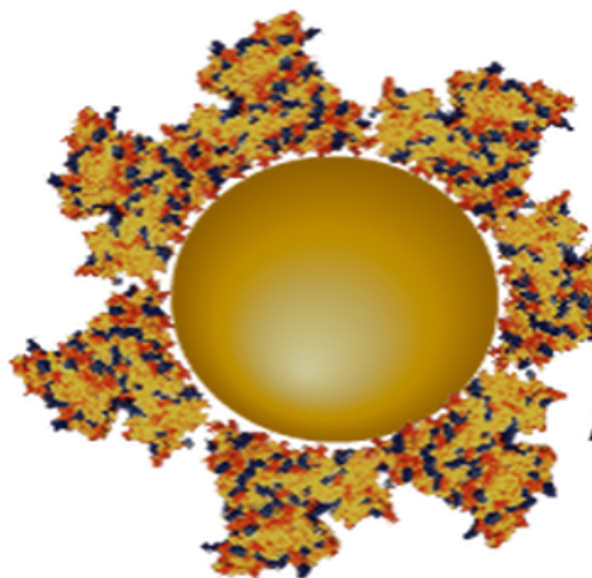

Figure 9: Albumin Nanoparticles

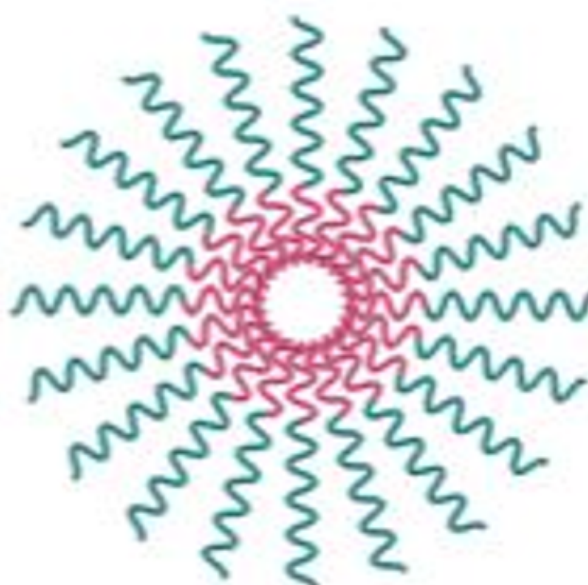

Figure 10: Polymeric micelles

several well-defined components around the inner core of 1-10 nm and physicochemical characteristics are similar to macromolecules. In comparison to many traditional polymers, dendrimers have structurally well-defined, low poly-dispersiveness despite their massive molecular mass (1000 to 800,000 kg). Dendritic branching leads to semi-globular constructions and enhances surface density. Dendrimers can also be used to form glycodendrimers, peptide dendrimers and silicon-based dendrimers. They are functionalized based on respective groups such as carbohydrates, peptides, and silicon present on it. The size of the dendrimer can affect its extravasation into the interstitial tis-

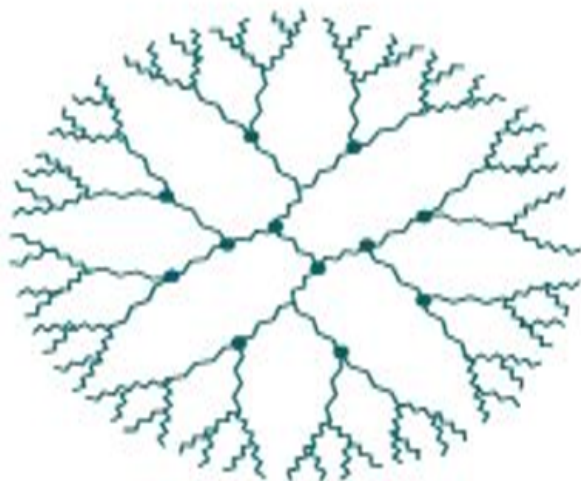

Figure 11: Dendrimers



Figure 12: Carbon nanotubes

sue around the endothelium to reach the target locations. When the size of PAMAM dendrimers for G0 to G4 is increased from 1.5 to 4.5 nm, the time of extravasation across the microvascular endothelial network is exponentially reduced. The dendrimers can be synthesized by divergence or convergence. Dendrimers are synthesized as the starting point for the former model and each generation is created. The disadvantages of this methodology are low yield production drug molecules can be combined with dendrimers in several ways. First, drugs can be inoculated in the void spaces of the interior of the dendrimer physically. Secondly, the networks of dendrimers can be developed. Passive PAMAM/indomethacin complex targeting effectiveness was found at inflammatory locations in arthritis rats at 2.29 times greater than free Quintana drugs and additionally altered PAMAM dendrimer-containing folate is used to target tumor cells that overexpress the receptors of folate with greater affinities. The diagrammatic representation of Dendrimers was illustrated in Figure 11, (Baughman, 2002).

Carbon nanotubes

Carbon nanotubes (CNTs) are cylindrical nanostruc-

tures of carbon with a single-wall or multi-wall category of carbons. These carbon-based NPs are significance in the medical field. CNTs have unique chemical, mechanical and electrical characteristics. Two primary kinds of carbon nanotubes are available with high perfection in structure. Single-walled Nanos (SWNTs) are composed of a single sheet of graphite rolled up in a cylindrical tube. Multi-walled nanotubes (MWNTs) are a range of nanotubes wrapped like the tree trunk rings regarding the construction similarity of a single sheet of graphite, which is the zero-band-gap semiconductor, it can be metal or semi-conductive based on the direction of the sheet, which rolls the sheet into a nanotube. The diagrammatic representation of Carbon nanotubes was illustrated in Figure 12, (Saeedi *et al.*, 2019).

Spongosomes and Cubosomes

Spongosomes and cubosomes were other types of membrane-type nanoparticles. These sponsors are irregularly structured by the 3D membrane, whereas cubosomes are often more coordinated in their structural arrangement with lattice membrane systems cubosomes are known to be more stable than liposomes and have greater ability to encapsulate hydrophobic chemotherapeutic agents because of their liquid crystalline membrane structure. Several proteins can readily be trapped in their water channels that help to ensure a better stability profile against enzymatic degradation because of their different versatile features, including customized nanochannel sizes, morphological forms, and tunable inner structural organizations, the cubosomes are known as proteoliposomes and have different structural benefits over other nana-compatible bio carriers. These are versatile, lipid crystalline tuneable nanoparticles that are extremely useful in prospective applications like therapeutic agent encapsulation, extraction, diagnostic and even tissue engineering. The Nanosystems was identified to have appropriate features such as blood-brain barrier permeation and targeted distribution in preferable regions of the brain. A combination of the cationic surfactant bromide and a lipid, such as a cetyltrimethylammonium, was used to fabricate vesicles as nanocarriers of various active constituents. These nano delivery systems have some drawbacks, which include the difficulty of optimizing different parameters like increase loading capacity, and improvement unloading the drug and the bioavailability of these new lipid-based distribution technologies. The swelling of fluid and water domains, which is another factor that possesses the negative impact of decreasing the encapsulation power of therapeutic molecules in these lipid com-

partments, which was another significant factor to consider in these delivery systems. It was observed that by applying a heat stimulus to the structural unit of these distribution systems causes reorganization into more effectively, a double diamond cubic lattice forming from the lipid membrane is the resulting structural arrangement. In this prospect, the inner abilities, surface area and functional features of these nanocrystalline self-assembled lipid particles, macromolecules, and other active ingredients need to be studied further (Wakaskar, 2018).

CONCLUSIONS

Parkinson's disease is a neurodegenerative disorder that is diagnosed clinically based on its motor characteristics, with commonly recognized non-motor symptoms. Etiology remains a mystery but includes a combination of risk factors like genetics and the environment, most commonly age and sex. Factors associated with enhanced mortality may include Parkinsonism severity, Parkinsonism exacerbating rate, whereas no neuroprotective therapy is still available, there are many medical and surgical therapies available for both the motor and the non-motor characteristics which can be utilized at various phases during the disease.

We can see better alternatives in the coming years with various continuing studies for emerging therapies. The efficiency of cellular uptake and specific transportation of drugs and/or imaging agents to target bodies, tissues and cells are common issues in either the diagnosis or therapy of various illnesses. Neurodegenerative illnesses are present complicated issues since the brain targeting remains a still unsolved challenge in the field of science, because of the existence of the blood-brain barrier, a tightly packaged cell layer which avoids undesirable substance entering the brain. The review also discussed on nanotechnology, it is multidisciplinary field has been engaged to achieving a technological achievement and is rapidly moving from idea to fact. The significant feature of this technology is the flexibility in modifying or changing nanoparticles to satisfy the requirements of pathological circumstances for therapeutic effects

Engineered nanomaterials, objects 1-100nm in size, provide interesting biomedical tools that are capable of solving these issues.

REFERENCES

Baughman, R. H. 2002. Carbon Nanotubes—the Route Toward Applications. *Science*, 297(5582):787–792.

Boas, U., Heegaard, P. M. H. 2004. Dendrimers in drug research. *Chemical Society Reviews*, 33(1):43–63.

Bulck, M. V., Sierra-Magro, A., Alarcon-Gil, J., Perez-Castillo, A., Morales-Garcia, J. 2019. Novel Approaches for the Treatment of Alzheimer's and Parkinson's Disease. *International Journal of Molecular Sciences*, 20(3):719–719.

Caviness, J. N. 2014. Pathophysiology of Parkinson's disease behavior - a view from the network. *Parkinsonism & Related Disorders*, 20(13):70012–70021.

Chemla, Y. R., Grossman, H. L., Poon, Y., McDermott, R., Stevens, R., Alper, M. D., Clarke, J. 2000. Ultrasensitive magnetic biosensor for homogeneous immunoassay. *Proceedings of the National Academy of Sciences*, 97(26):14268–14272.

Collins, L. M., Toulouse, A., Connor, T. J., Nolan, Y. M. 2012. Contributions of central and systemic inflammation to the pathophysiology of Parkinson's disease. *Neuropharmacology*, 62(7):2154–2168.

Hartmann, C. J., Fliegen, S., Groiss, S. J., Wojtecki, L., Schnitzler, A. 2019. An update on best practice of deep brain stimulation in Parkinson's disease. *Therapeutic Advances in Neurological Disorders*, 12.

Hattori, N., Takeda, A., Takeda, S., Nishimura, A., Kato, M., Mochizuki, H., Takahashi, R. 2018. Efficacy and safety of adjunctive rasagiline in Japanese Parkinson's disease patients with wearing-off phenomena: A phase 2/3, randomized, double-blind, placebo-controlled, multicenter study. *Parkinsonism & Related Disorders*, 53:21–27.

Kim, K. Y. 2007. Nanotechnology platforms and physiological challenges for cancer therapeutics. *Nanomedicine: Nanotechnology, Biology and Medicine*, 3(2):103–110.

Kim, T. Y. 2004. Phase I and Pharmacokinetic Study of Genexol-PM, a Cremophor-Free, Polymeric Micelle-Formulated Paclitaxel, in Patients with Advanced Malignancies. *Clinical Cancer Research*, 10(11):3708–3716.

Koo, O. M., Rubinstein, I., Onyuksel, H. 2005. Role of nanotechnology in targeted drug delivery and imaging: a concise review. *Nanomedicine: Nanotechnology, Biology and Medicine*, 1(3):193–212.

Lajurkar, S. V., Nade, V. S., Bhoir, P. V., Kardus, N. A. 2018. Current Status and Novel Strategies for Prevention and Treatment of Parkinson. *Biology, Medicine, Psychology*. Corpus ID: 212532823.

Leonard, R. C. F., Williams, S., Tulpule, A., Levine, A. M., Oliveros, S. 2009. Improving the therapeutic

- tic index of anthracycline chemotherapy: Focus on liposomal doxorubicin (Myocet™). *The Breast*, 18:218–224.
- Li, Q., Cai, T., Huang, Y., Xia, X., Cole, S., Cai, Y. 2017. A Review of the Structure, Preparation, and Application of NLCs, PNPs, and PLNs. *Nanomaterials*, 7:122–122.
- Muller, R. 2000. Solid lipid nanoparticles (SLN) for controlled drug delivery -a review of the state of the art. *European Journal of Pharmaceutics and Biopharmaceutics*, 50(1):161–177.
- Muller, T. 2015. Safinamide for symptoms of Parkinson's disease. *Drugs Today (Barc)*, 51(11):653–659.
- Pardridge, W. M. 2005. Drug and gene targeting to the brain via blood-brain barrier receptor-mediated transport systems. *International Congress Series*, 1277:49–62.
- Pires, A. O., Teixeira, F. G., Mendes-Pinheiro, B., Serra, S. C., Sousa, N., Salgado, A. J. 2017. Old and new challenges in Parkinson's disease therapeutics. *Progress in Neurobiology*, 156:69–89.
- Poewe, W., Antonini, A., Zijlmans, J. C., Burkhard, P. R., Vingerhoets, F. 2010. Levodopa in the treatment of Parkinson's disease: an old drug still going strong. *Clinical Interventions in Aging*, 229(5).
- Saeedi, M., Eslamifar, M., Khezri, K., Dizaj, S. M. 2019. Applications of nanotechnology in drug delivery to the central nervous system. *Biomedicine & Pharmacotherapy*, 111:666–675.
- Sahoo, S. K., Labhasetwar, V. 2003. Nanotech approaches to drug delivery and imaging. *Drug Discovery Today*, 8(24):2903–2912.
- Vinogradov, S. V., Batrakova, E. V., Kabanov, A. V. 2004. Nanogels for Oligonucleotide Delivery to the Brain. *Bioconjugate Chemistry*, 15(1):50–60.
- Wakaskar, R. R. 2018. A general overview of lipid-polymer hybrid nanoparticles, dendrimers, micelles, liposomes, spongosomes and cubosomes. *Journal of Drug Targeting*, 26(4):311–318.
- Youdim, M. B. H., Edmondson, D., Tipton, K. F. 2006. The therapeutic potential of monoamine oxidase inhibitors. *Nature Reviews Neuroscience*, 7(4):295–309.
- Zaki, N. 2012. CNS Delivery of Drugs: Challenges and Chances. *Journal of Bioequivalence & Bioavailability*, (6):4–4.
- Zara, G. P., Cavalli, R., Bargoni, A., Fundarò, A., Vighetto, D., Gasco, M. R. 2002. Intravenous Administration to Rabbits of Non-stealth and Stealth Doxorubicin-loaded Solid Lipid Nanoparticles at Increasing Concentrations of Stealth Agent: Pharmacokinetics and Distribution of Doxorubicin in Brain and Other Tissues. *Journal of Drug Targeting*, 10(4):327–335.
- Zeuner, K. E., Schäffer, E., Hopfner, F., Brüggemann, N., Berg, D. 2019. Progress of Pharmacological Approaches in Parkinson's Disease. *Clinical Pharmacology & Therapeutics*, 105(5):1106–1120.
- Zhang, L., Hou, S., Mao, S., Wei, D., Song, X., Lu, Y. 2004. Uptake of folate-conjugated albumin nanoparticles to the SKOV3 cells. *International Journal of Pharmaceutics*, 287(1-2):155–162.